

# ABOVE-GRADE FLASHING DRAIN

833 series

Finish Line™

## SPECIFICATION

Sioux Chief 883 series Finish Line adjustable above-grade flashing drain shall be used where necessary in drainage systems. Flashing drain shall allow adjustment of 1.25" before the concrete pour, and 1.25" after the concrete pour. Flashing drain shall have an invertible flashing collar, and cast iron no-hub or push-joint connection. Strainer shall be heel-proof and meet applicable load requirements for intended use. Trap primer port shall be threaded 1/2" FIP for optional connection. Designed in accordance with ASME A112.6.3-2001

## MATERIALS

ring/strainer: nickel-bronze, 304 stainless steel  
 head adapter, coring sleeve: ABS  
 coring plug: high-impact polymer  
 flashing collar: ABS  
 base adapter : cast iron

## STRAINER LOAD RATING

nickel-bronze: 1,000 lbs. (light duty, pedestrian traffic)  
 stainless steel: 2,000 lbs. (light duty, pedestrian traffic)

## STRAINER FREE AREA

	large	standard
round:	11.75 in <sup>2</sup>	7.5 in <sup>2</sup>
square:	16.4 in <sup>2</sup>	12.75 in <sup>2</sup>

## DIMENSIONS

A: connection	2", 3", or 4"
B: ring/strainer diameter	
round	5 1/2" or 6 1/2"
square	5 7/8" or 7"
C: flange diameter	8 1/2"
D: pre-pour adjustment	
no-hub	4 7/8" - 7 5/16"
push-joint	5 1/4" - 7 11/16"
E: post-pour adjustment	
round	0" - 1 1/4"
square	5/16" - 1 1/4"
Trap primer port	1/2" FIP thread, plugged

Item # Submitted _____
Job Name _____
Location _____
Engineer _____
Contractor _____
PO# _____ TAG _____



833-23NR

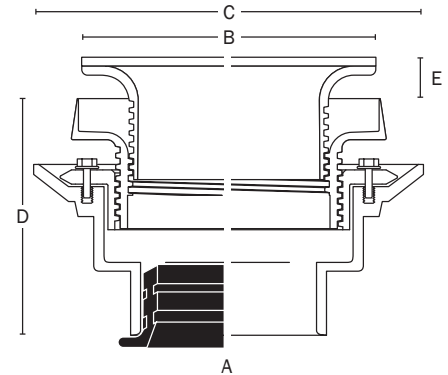

Models 833-23NR, 833-23NQ are UPC listed

Create Item Number

**833- ABCD**

e.g. 833-23NR = Finish Line flashing drain with 3" no-hub connection with vandal resistant nickel ring and strainer

<p><b>A</b> CONNECTION TYPE</p> <p><input type="checkbox"/> 2 no-hub</p> <p><input type="checkbox"/> 6 push-joint</p>	<p><b>C</b> RING &amp; STRAINER</p> <p><input type="checkbox"/> NR round nickel-bronze</p> <p><input type="checkbox"/> NQ square nickel-bronze</p> <p><input type="checkbox"/> SR round stainless steel</p> <p><input type="checkbox"/> SQ square stainless steel</p>	<p><b>ACCESSORIES</b></p> <p><input type="checkbox"/> 832-UM stainless steel debris screen <sup>4</sup></p> <p><input type="checkbox"/> 832-S4 shim kit</p> <p><input type="checkbox"/> 832-EX4 ductile iron extension nipple <sup>4,5</sup></p> <p><input type="checkbox"/> 832-W locating bristle kit</p> <p><input type="checkbox"/> 863-FN nickel-bronze funnel</p> <p><input type="checkbox"/> 863-FA aluminum funnel</p> <p><input type="checkbox"/> 863-FNO oval nickel-bronze funnel</p> <p><sup>4</sup> For use with large top only</p> <p><sup>5</sup> Extends heads 2" (min) to 4" (max) above coring sleeve</p>
<p><b>B</b> CONNECTION / TOP SIZE</p> <p><input type="checkbox"/> 2 2" conn. / large top</p> <p><input type="checkbox"/> 25 2" conn. / standard top</p> <p><input type="checkbox"/> 3 3" conn. / large top</p> <p><input type="checkbox"/> 35 3" conn. / standard top</p> <p><input type="checkbox"/> 4 4" conn. / large top</p>	<p><b>D</b> OPTIONS (FACTORY INSTALLED)</p> <p><input type="checkbox"/> V vandal-resistant strainer screws</p> <p><input type="checkbox"/> H hinged strainer <sup>1</sup></p> <p><input type="checkbox"/> E 1 3/8" extended strainer rim <sup>2</sup></p> <p><input type="checkbox"/> B complies with Buy American Act <sup>3</sup></p> <p><sup>1</sup> Available for large nickel-bronze or stainless steel only</p> <p><sup>2</sup> Available for large, round nickel-bronze strainers only</p> <p><sup>3</sup> Available for round nickel-bronze strainers only</p>	