

# UNIVERSAL BRACKETING SYSTEM

523-24 series

Power Bar™

Item # Submitted	_____
Job Name	_____
Location	_____
Engineer	_____
Contractor	_____
PO#	_____ TAG _____

## SPECIFICATION

Sioux Chief 523 Series Power Bar universal bracketing system shall be used where necessary for supporting pipe or stub outs. Bracket shall be corrosion resistant, adjust telescopically from 14"-26", and have dual fastening tabs on each end. Pilot holes for #6-#10 screws shall be provided on three sides of the bracket. System shall include screws for fastening tabs, and optional adjustable channel clamps with elastomer inserts for fastening any pipe, tube, cable, etc. System shall be approved for use with copper tube, CPVC tube, PEX/PB tube, steel pipe, CSST lines, plastic or steel conduit, and low voltage DataCom cable. System shall be UV resistant, and UPC listed.

## MATERIALS

*bracket:* 20 gauge zinc-plated steel  
*channel clamp (black):* nylon 66, V2 flame rating  
*channel clamp (orange):* polyvinylidene fluoride (PVDF), meets ASTM E84 25/50 & UL94 V-0 flame rating  
*clamp insert:* thermoplastic elastomer  
*screws:* #8 × 1" Phillips, panhead, drill-tip, zinc-plated



523-2414

## SAFE WORKING LOAD\*

bracket		nylon channel clamps		PVDF channel clamps	
span	safe load	temp.	safe load	temp.	safe load
14"	150 lbs.	-10°-130°F	70 lbs.	-10°-130°F	50 lbs.
17"	115 lbs.	131°-179°F	38 lbs.	131°-179°F	35 lbs.
21"	80 lbs.	180°-220°F	12 lbs.	180°-220°F	25 lbs.
24"	45 lbs.	220°F +	—	220°F +	—

\*Safe working load = one-half failure of centrally hung load

## INSTALLATION

Adjust bracket telescopically to desired length (bracket must have a minimum overlap of 2"). Fastening all four tabs to building member. Slide channel clamps (if applicable) to desired location along bracket. Place conduit between clamp posts, and engage clamp bridge. Ratchet bridge of channel clamp down over both posts evenly. It is permissible to use one bracket section and fasten directly through channel.

## DIMENSIONS

A: Channel clamp post	1 7/8"
B: Channel clamp capacity	1/4"-1 1/8"
C: Channel clamp base	1 7/8"
D: Pilot hole spacing	0.203" on center
E: Tab length	1"
F: Tab hole diameter	0.15"
G: Outer/inner bracket length	14"
H: Bracket height	0.529"
I: Bracket width	0.602"
J: Pilot hole diameter	0.1"
K: Metal thickness	0.036"
L: Tab screw length	1"

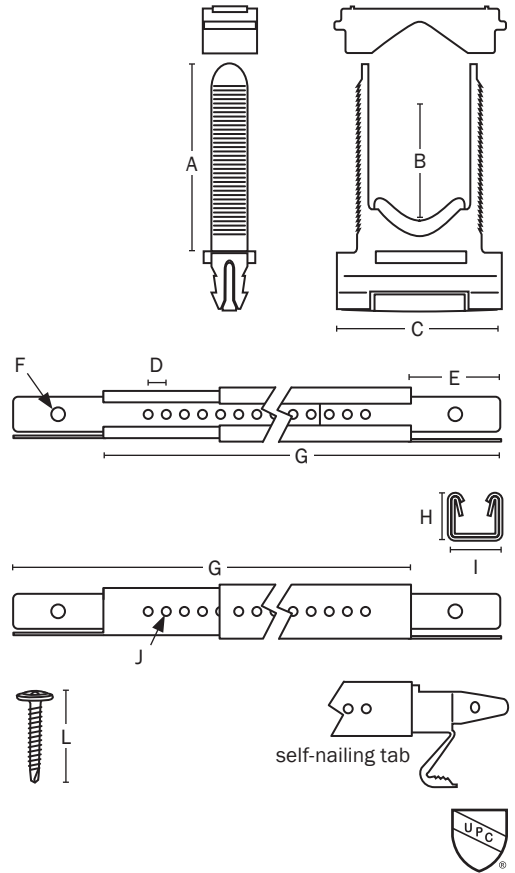

Create Item Number

**523 A**

e.g. 523-2424 = 14"-26" adjustable steel bracket with two nylon channel clamps and four screws.

- |   |  |
|---|--|
| <b>A</b> BRACKET CONFIGURATION  | <input type="checkbox"/> -2404 no channel clamps; six screws                             |
| <input type="checkbox"/> -24 no channel clamps; no screws                       | <input type="checkbox"/> -2420 two nylon channel clamps; no screws                       |
| <input type="checkbox"/> -24N no channel clamps; self-nailing tabs; four screws | <input type="checkbox"/> -2420N two nylon channel clamps; self-nailing tabs; four screws |
| <input type="checkbox"/> -2414 one nylon channel clamp; four screws             | <input type="checkbox"/> -2434 three nylon channel clamps; four screws                   |
| <input type="checkbox"/> -2424 two nylon channel clamps; four screws            |  |
| <input type="checkbox"/> F2424 two E84 channel clamps; four screws              |  |