

ADJUSTABLE BRACKETING SYSTEM

523 series

Power Bar Mini Strut™

SPECIFICATION

Sioux Chief 523-2MS series Power Bar Mini Strut shall be used where necessary for hanging pipes overhead from 3/8" threaded rod. Bracket shall be corrosion resistant. System shall include adjustable channel clamps with elastomer inserts for fastening any pipe, tube, cable, etc. up to 2" maximum diameter when used with Sioux Chief Touchdown Clamps or Sioux Chief Touchdown II clamps. System shall be approved for use with insulated or non-insulated copper tube, CPVC tube, PEX/PB tube, steel pipe, CSST lines, plastic or steel conduit and low voltage DataCom cable. System shall be UV resistant.

Item # Submitted	_____
Job Name	_____
Location	_____
Engineer	_____
Contractor	_____
PO#	_____ TAG _____

MATERIALS

bracket: 20-gauge galvanized steel
channel clamp: nylon, UL94 V2 flame rating
clamp insert: thermoplastic elastomer

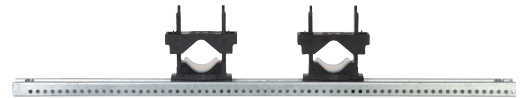

523-2MS2

SAFE WORKING LOAD*

<i>bracket:</i> 70 lbs.	<i>channel clamp:</i> temp.	<i>safe load</i>
	-10-130°	70 lbs.
	131-179°	38 lbs.
	180-220°	12 lbs.

*Safe working load = 1/2 failure of centrally hung load

INSTALLATION

Once adjustable clamps are installed in bracket channel, insert 3/8" all-thread rod to suspend bracket, using approved 3/8" hex nuts and washers. When specified, use hardware above and below bracket channel. Move adjustable clamps to desired location within bracket channel. Place conduit between clamp posts and engage clamp bridge. Ratchet bridge of channel clamp down over both posts evenly. It is permissible to install optional Sioux Chief Touchdown II adjustable clamp or any approved galvanized two-hole pipe strap to bracket channel by installing conduit into pipe strap and then securing pipe strap to bracket with approved #6-#10 screws.

DIMENSIONS

A: Channel clamp post	1 7/8"
B: Channel clamp capacity	1/4" - 1 1/8"
C: Channel clamp base	1 7/8"
D: Pilot hole spacing	0.203" on center
E: All-thread hole diameter	0.39"
F: Bracket length	13 5/8"
G: Bracket height	0.529"
H: Bracket width	0.602"
I: Pilot hole diameter	0.1"
J: Metal thickness	0.036"
K: Spacing between all-thread holes	12 3/4" on center

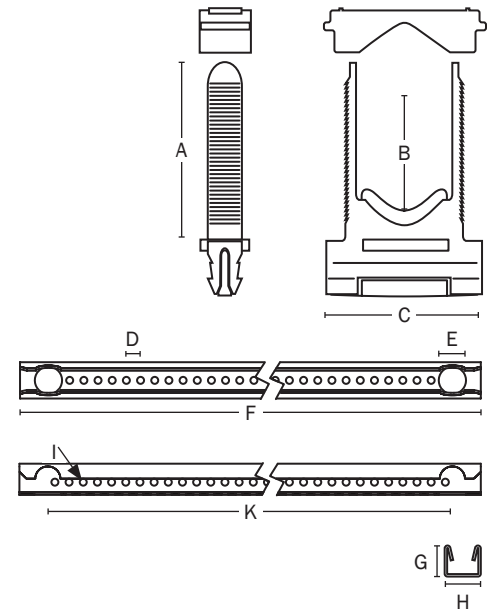

Create Item Number

523-2MS A

e.g. 523-2MS4 = steel bracket with four channel clamps.

- A BRACKET CONFIGURATION
- _ Bracket only, no channel clamps
- 2 Bracket, two channel clamps
- 3 Bracket, three channel clamps
- 4 Bracket, four channel clamps