

# AUTOMATIC TRAP PRIMER VALVE

695 series

Prime Perfect™

Item # Submitted	_____
Job Name	_____
Location	_____
Engineer	_____
Contractor	_____
PO#	_____ TAG _____

## SPECIFICATION

Where replenishment of water in floor drain traps is required; trap primer valves shall be 1/2" FIP inlet x 1/2" MIP outlet, automatic trap primer valves which activate with a 10 PSIG pressure drop between 30–150 PSIG. Water release shall be factory set. Trap primer valve shall have large port openings and a non-corrosive brass finish. Must be UPC/IAPMO listed, and ASSE certified to the ASSE 1018 standard.

## WORKING PRESSURE

working pressure: 30–250 PSIG

## OPERATING PRESSURE

Activates with a 10 PSIG pressure drop at 30–150 PSIG

## INSTALLATION

Install to a convenient 1/2"–1 1/2" nominal water line, nearest the trap or traps to be served. Install in the upright, vertical position only. Install at least 6" (152.4 mm) above the grid of the floor drain or the flood rim of the sink or fixture which the trap serves. Install near plumbing fixtures to insure a full pressure drop of 10 PSI or more. If the trap primer is installed too far upstream in the system, the pressure drop may not be enough for activation. To help prevent sediment buildup, install a vertical loop that rises above the supply line tee. (see figure 1) Flush trap primer branch line prior to installing the trap primer. Install MIP adapter. Thread on trap primer. Install FIP union to bottom. Use PTFE tape sealant on both connections. Do not use pipe dope. Do not solder or braze directly to trap primer or fittings installed in trap primer. Water discharge is factory set—no adjustment is required on normal installations. However, for static pressures over 100 PSI, adjustments may be necessary. First loosen the nipple locknut (10, below), then turn the nipple (19, below) counter-clockwise until the trap primer starts dripping, turn the nipple clockwise 1/4-turn, and re-tighten nipple locknut.

## DIMENSIONS

Inlet	1/2" FIP
Outlet	1/2" MIP
Diameter	2 3/4"
Length	5 1/4"

## COMPONENTS

1: Cap, brass-plated Zamac No. 3	11: Vacuum breaker
2: Stainless steel screws	12: Sediment screen
3: Diaphragm	13: Diaphragm stop washer
4: Valve stem spring	14: Diaphragm spring retainer
5: Valve stem nut	15: Valve stem
6: Rubber valve disc	16: Diaphragm spring
7: Valve stem guide	17: Valve washer
8: Body, brass-plated Zamac No. 3	18: Diaphragm adjustment nut
9: Nipple seat washer	19: Brass nipple
10: Nipple locknut	



695-01

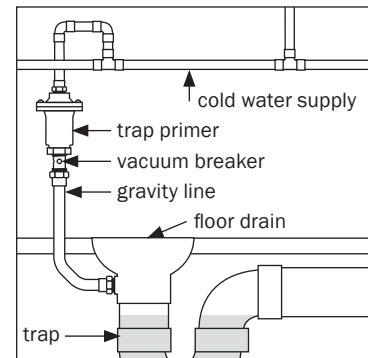
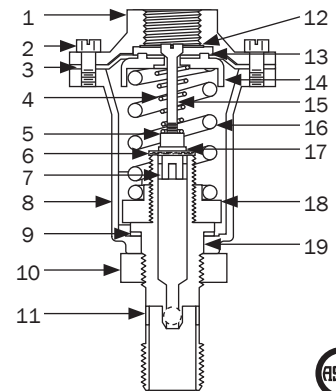

figure 1



## 695-01

ACCESSORIES	
<input type="checkbox"/> 695-Y52 wye splitter	<input type="checkbox"/> 695-D40 four 1/4" male sweat branches
<input type="checkbox"/> 695-D20 two 1/4" male sweat branches	<input type="checkbox"/> 695-D432 two 1/4" male sweat branches, two spin-closed branches
<input type="checkbox"/> 695-D30 three 1/4" male sweat branches	<input type="checkbox"/> 695-D432F four 1/2" FIP branches with two plugs
	<input type="checkbox"/> 695-D4325 two 1/2" female sweat branches, two spin-closed branches