

ADJUSTABLE FLOOR DRAIN WITH SQUARE CAST IRON GRATE

862 SERIES

SPECIFICATION

Sioux Chief 862 Series coated cast iron adjustable floor drain with anchor flange, weep holes, clamping collar, adjustable square cast iron top with secured, heel-resistant and vandal-resistant grate, 1/2" NPT trap primer (plugged) and bottom outlet. Designed in accordance with ASME A112.6.3

General purpose floor drain for use in warehouses, mechanical rooms, parking garages, and other areas with heavy-duty traffic.

MATERIALS

Drain body: cast iron
Clamping collar: cast iron
Head/grate: cast iron

LOAD RATING

Extra Heavy-duty (7,500 - 10,000 lbs). Heel-resistant

DIMENSIONS

A: Connection size (No-Hub) 2", 3", 4"
B: Top diameter 9"
C: Strainer adjustment 1.55" - 2.55"
 Strainer free-area 24.0 in²

ITEM # SUBMITTED	_____
JOB NAME	_____
LOCATION	_____
ENGINEER	_____
CONTRACTOR	_____
PO#	_____ TAG _____

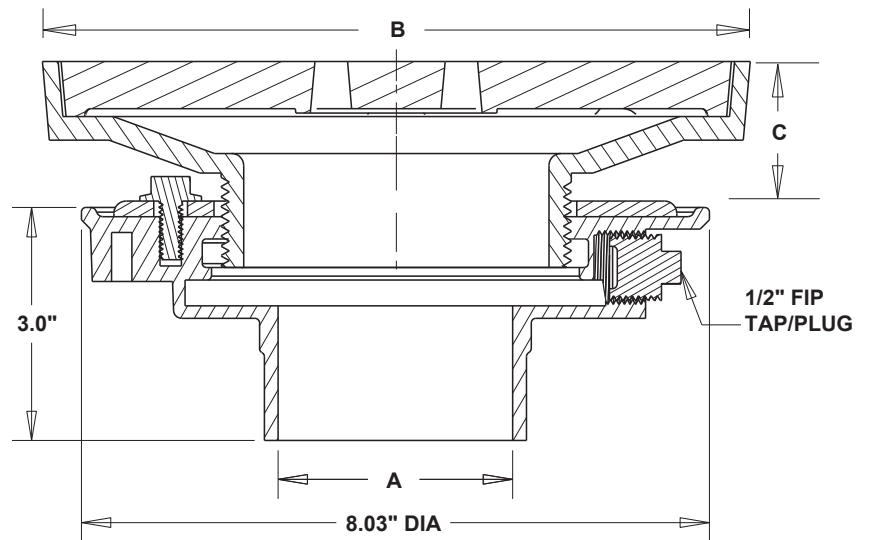

Create Item Number

862-ABC

e.g. **862-239IQB:** Floor drain - 3" No-Hub connection, square cast iron head/strainer with debris bucket

CONNECTION TYPE A

2 = No-Hub outlet
6 = Push-Joint outlet

CONNECTION SIZE B

29IQ = 2"
39IQ = 3"
49IQ = 4"

OPTIONS C

A = Epoxy-coated body/collar
B = Debris bucket
X = Drain head extension adapter